



REQUEST FOR QUOTATION NO. RFQ26/03216:

SELECTING A COMPANY FOR PROFESSIONAL CONSULTANCY SERVICES FOR DETAILED TECHNICAL DESIGN AND COSTS ESTIMATION FOR VOLUNTARY WASTE COLLECTION CENTERS

SECTION 1: REQUEST FOR QUOTATION (RFQ)

UNDP through „Enabling an Inclusive Green Transition in the Republic of Moldova” Project, kindly requests your quotation for provision of **services for detailed technical design and costs estimation for Voluntary Waste Collection Centers (including all infrastructure)** as detailed in line items section of this RFQ.

This Request for Quotation comprises the following documents:

Section 1: This RFQ document generated by the online system

Section 2: General instructions

Section 3: Special instructions

Annex 1: Schedule of Requirements

Annex 2: Quotation Submission Form

Annex 3: Technical Offer and Financial Offer

Annex 4: Geometric plans and cadastral extracts of CAV

When preparing your quotation, please be guided by the RFQ Instructions and Data. Please note that quotations must be submitted directly in the system responding to the questions and uploading required documents by the date and time indicated in the online portal. It is your responsibility to ensure that your quotation is submitted before the deadline. Quotations received after the submission deadline outside the online portal, for whatever reason, will not be considered for evaluation.

Quotations must be submitted directly in Quantum NextGenERP supplier portal following the link: <http://supplier.quantum.partneragencies.org> using the profile you may have in the portal (please log in using your username and password).

Follow the instructions in the user guide to search for the tender using search filters, namely **Negotiation ID: UNDP-MDA-00921** and subscribe to the tender in order to get notifications in case of amendments of the tender document and requirements.

In case you have never registered before, follow this link to register a profile: <https://estm.fa.em2.oraclecloud.com/fscmUI/redwood/supplier-registration/register-supplier/register-supplier-verification?id=TUW16eK6qsD94MNMxATNMoyCOHny7FmchTkUZsdOqrAW4sy6L5xSAB033Q%3D%3D>

Please note that the access link to the Supplier registered profile is sent from Oracle within up to 3 days. In case you have not received the access link after 3 days since registration, you should address for support to UNDP at the email address: sc.md@undp.org. In case you encounter errors with registration (e.g. system states Supplier already is registered), you should address for support to UNDP at the email address: sc.md@undp.org.

Computer firewall could block *oracle* or *undp.org* extension and Suppliers might not receive the Oracle notifications. Please turn down any firewalls on your computers to ensure receipt of email notification.

Do not create a new profile if you already have one. Use the forgotten password feature in case you do not remember the password or the username from previous registration.

Should you require further clarifications on the application through the Quantum online portal, kindly contact the Procurement Unit at sc.md@undp.org. Please pay attention that the bid shall be submitted online through the Quantum system and any bid sent to the above email shall be disqualified.

Should you require further clarifications on the Request for Quotation, Terms of Reference or other requirements, kindly communicate using the messaging functionality in the portal.

Deadline for Submission of Offers (Date and Time), which is visible in the online procurement system will be final. System will not accept submission of any bid after that date and time. It is the responsibility of the bidder to make sure that the bid is submitted prior to this deadline for submission.

Bidders are advised to upload bid documents and to submit their offer a day prior or well before the date and time indicated under the deadline for submission of Offers. Do not wait until last minute. If Bidder faces any issue during submitting offers at the last minutes prior to the deadline for submission, UNDP may not be able to assist on such a short notice and will not be held liable in such instance. UNDP will not accept any offer that is not submitted directly through the System.

Thank you and we look forward to receiving your quotation.

UNDP Moldova

SECTION 2: GENERAL INSTRUCTIONS

Introduction	<p>Bidders shall adhere to all the requirements of this RFQ, including any amendments made in writing by UNDP. This RFQ is conducted in accordance with the UNDP Programme and Operations Policies and Procedures (POPP) on Contracts and Procurement</p> <p>Any Bid submitted will be regarded as an offer by the Bidder and does not constitute or imply the acceptance of the Bid by UNDP. UNDP is under no obligation to award a contract to any Bidder as a result of this RFQ.</p> <p>UNDP reserves the right to cancel the procurement process at any stage without any liability of any kind for UNDP, upon notice to the bidders or cancellation of the tender in the online portal.</p>
Deadline for the Submission of Quotation	<p>Deadline is indicated in the online portal.</p> <p>If any doubt exists as to the time zone in which the quotation should be submitted, refer to http://www.timeanddate.com/worldclock/.</p>
Method of Submission	<p>Quotations must be submitted as follows:</p> <p>NextGenERP supplier portal following this link: http://supplier.nextgenerp.partneragencies.org/ using the profile you may have in the portal.</p> <p>Follow the instructions in the user guide to search for the tender using Negotiation ID. In case you have never registered before, follow this link to register a profile: https://estm.fa.em2.oraclecloud.com/fscmUI/redwood/supplier-registration/register-supplier/register-supplier-verification?id=TUW16eK6qsD94MNMxATNMoyCOHny7FmchTkUZsdOqrAW4sy6L5xSAB033Q%3D%3D</p> <p>Do not create a new profile if you already have one. Use the forgotten password feature in case you do not remember the password or the username from previous registration.</p> <ul style="list-style-type: none"> ▪ File Format: All attachments must be in PDF format unless otherwise instructed by UNDP. ▪ File names must be in Latin alphabet/keyboard and clearly indicate the content of the document to facilitate review. ▪ All files must be free of viruses and not corrupted.
Cost of preparation of quotation	<p>UNDP shall not be responsible for any costs associated with a Supplier's preparation and submission of a quotation, regardless of the outcome or the manner of conducting the selection process.</p>
Supplier Code of Conduct, Fraud, Corruption,	<p>All prospective suppliers must read the United Nations Supplier Code of Conduct and acknowledge that it provides the minimum standards expected of suppliers to the UN. The Code of Conduct, which includes principles on labour, human rights, environment and ethical conduct may be found at: https://www.un.org/Depts/ptd/about-us/un-supplier-code-conduct</p> <p>Moreover, UNDP strictly enforces a policy of zero tolerance on proscribed practices, including fraud, corruption, collusion, unethical or unprofessional practices, and obstruction of UNDP vendors and requires all bidders/vendors to observe the highest standard of ethics during the procurement process and contract implementation. UNDP's Anti-Fraud Policy can be found at http://www.undp.org/content/undp/en/home/operations/accountability/audit/office_of_audit_and_investigation.html#anti</p>

<p>Gifts and Hospitality</p>	<p>Bidders/vendors shall not offer gifts or hospitality of any kind to UNDP staff members including recreational trips to sporting or cultural events, theme parks or offers of holidays, transportation, or invitations to extravagant lunches, dinners or similar. In pursuance of this policy, UNDP: (a) Shall reject a bid if it determines that the selected bidder has engaged in any corrupt or fraudulent practices in competing for the contract in question; (b) Shall declare a vendor ineligible, either indefinitely or for a stated period, to be awarded a contract if at any time it determines that the vendor has engaged in any corrupt or fraudulent practices in competing for, or in executing a UNDP contract.</p>
<p>Conflict of Interest</p>	<p>UNDP requires every prospective Supplier to avoid and prevent conflicts of interest, by disclosing to UNDP if you, or any of your affiliates or personnel, were involved in the preparation of the requirements, design, specifications, cost estimates, and other information used in this RFQ. Bidders shall strictly avoid conflicts with other assignments or their own interests, and act without consideration for future work. Bidders found to have a conflict of interest shall be disqualified.</p> <p>Bidders must disclose in their Bid their knowledge of the following: a) If the owners, part-owners, officers, directors, controlling shareholders, of the bidding entity or key personnel who are family members of UNDP staff involved in the procurement functions and/or the Government of the country or any Implementing Partner receiving goods and/or services under this RFQ.</p> <p>The eligibility of Bidders that are wholly or partly owned by the Government shall be subject to UNDP’s further evaluation and review of various factors such as being registered, operated and managed as an independent business entity, the extent of Government ownership/share, receipt of subsidies, mandate and access to information in relation to this RFQ, among others. Conditions that may lead to undue advantage against other Bidders may result in the eventual rejection of the Bid.</p>
<p>Currency of Quotation</p>	<p>Quotations shall be quoted only in the currency indicated in the system:</p> <p>Moldovan Leu (MDL) for local suppliers and US Dollars (USD) for international suppliers.</p> <p>For evaluation purposes, all the rates shall be recalculated at UN Operational Rate of Exchange (to be found at https://treasury.un.org/operationalrates/OperationalRates.php) indicated in the portal.</p> <p>In case of contract award to a local company, payments will be made in Moldovan Leu based on UN Operational Rate of Exchange valid on the date of money transfer, as per the “payment terms and conditions” stipulated in this solicitation document: https://treasury.un.org/operationalrates/OperationalRates.php</p> <p>UNDP shall not be kept liable for any fluctuations of the exchange market during contract implementation, the Contractor being legally responsible to register any loss/gain of currency exchange resulting from payments against the Contract in accordance with the national legislation.</p>
<p>Joint Venture, Consortium or Association</p>	<p>If the Bidder is a group of legal entities that will form or have formed a Joint Venture (JV), Consortium or Association for the Bid, they shall confirm in their Bid that : (i) they have designated one party to act as a lead entity, duly vested with authority to legally bind the members of the JV, Consortium or Association jointly and severally, which shall be evidenced by a duly notarized Agreement among the legal entities, and submitted with the Bid; and (ii) if they are awarded the contract, the contract shall be entered into, by and between UNDP and the designated lead entity, who shall be acting for and on behalf of all the member entities comprising the joint venture, Consortium or Association. Refer to Clauses 19 – 24 under Solicitation policy for details on the applicable provisions on Joint Ventures, Consortium or Association.</p>

Only one Bid	<p>The Bidder (including the Lead Entity on behalf of the individual members of any Joint Venture, Consortium or Association) shall submit only one Bid, either in its own name or, if a joint venture, Consortium or Association, as the lead entity of such Joint Venture, Consortium or Association.</p> <p>Bids submitted by two (2) or more Bidders shall all be rejected if they are found to have any of the following:</p> <ul style="list-style-type: none"> a) they have at least one controlling partner, director or shareholder in common; or b) any one of them receive or have received any direct or indirect subsidy from the other/s; or b) they have the same legal representative for purposes of this RFQ; or c) they have a relationship with each other, directly or through common third parties, that puts them in a position to have access to information about, or influence on the Bid of, another Bidder regarding this RFQ process; d) they are subcontractors to each other's Bid, or a subcontractor to one Bid also submits another Bid under its name as lead Bidder; or e) some key personnel proposed to be in the team of one Bidder participates in more than one Bid received for this RFQ process. This condition relating to the personnel, does not apply to subcontractors being included in more than one Bid.
Price variation	<p>No price variation due to escalation, inflation, fluctuation in exchange rates, or any other market factors shall be accepted at any time during the validity of the quotation after the quotation has been received.</p>
Alternative Quotes	<p>If alternative quote is permitted, it may be submitted only if a conforming quote to the RFQ requirements is submitted. Where the conditions for its acceptance are met, or justifications are clearly established, UNDP reserves the right to award a contract based on an alternative quote. If multiple/alternative quotes are being submitted, they must be clearly marked as "Main Quote" and "Alternative Quote" directly in the portal and in any supporting document as relevant.</p>
Contact Person for correspondence, notifications and clarifications	<p>Must be submitted directly in the portal using the messaging functionality.</p> <p>Any delay in UNDP's response shall be not used as a reason for extending the deadline for submission, unless UNDP determines that such an extension is necessary and communicates a new deadline to the Proposers.</p>
Right not to accept any quotation	<p>UNDP is not bound to accept any quotation, nor award a contract or Purchase Order</p>
Right to vary requirement at time of award	<p>At the time of award of Contract or Purchase Order, UNDP reserves the right to vary (increase or decrease) the quantity of services and/or goods, by up to a maximum twenty-five per cent (25%) of the total offer, without any change in the unit price or other terms and conditions.</p>
Publication of Contract Award	<p>UNDP will publish the contract awards on the websites of the CO and the corporate UNDP Web site.</p>
Policies and procedures	<p>This RFQ is conducted in accordance with UNDP Programme and Operations Policies and Procedures</p>
UNGM registration	<p>Any Contract resulting from this RFQ exercise will be subject to the supplier being registered at the appropriate level on the United Nations Global Marketplace (UNGM) website at www.ungm.org. The Bidder may still submit a quotation even if not registered with the UNGM, however, if the Bidder is selected for Contract award, the Bidder must register on the UNGM prior to contract signature.</p>



SECTION 3: SPECIAL INSTRUCTIONS

General Conditions of Contract	<p>Any Purchase Order or contract that will be issued as a result of this RFQ shall be subject to one of the General Conditions of Contract below as applicable in each case specified in the Requirements section</p> <p>Applicable GTC: <input checked="" type="checkbox"/> General Terms and Conditions for Contracts (for Goods and/or Services)</p> <p>Applicable Terms and Conditions and other provisions are available at UNDP/How-we-buy</p>
Special Conditions of Contract	<p><input checked="" type="checkbox"/> Cancellation of PO/Contract if the delivery/completion is delayed by thirty (30) calendar days</p> <p><input checked="" type="checkbox"/> Liquidated damages shall be imposed as follows: If the Contractor fails to complete the services enlisted in Deliverables 1-3, within one hundred fifty (150) calendar days, 2.5% of the total contract amount will be deducted out of the final invoice for each week of delay. Max. number of weeks of delay four (4). Once the total amount of liquidated damages is equal to ten percent (10%) of the total contract amount, UNDP reserves the right to terminate the contract.</p>
Duties and taxes	<p>Article II, Section 7, of the Convention on the Privileges and Immunities provides, inter alia, that the United Nations, including UNDP as a subsidiary organ of the General Assembly of the United Nations, is exempt from all direct taxes, except charges for public utility services, and is exempt from customs restrictions, duties, and charges of a similar nature in respect of articles imported or exported for its official use. All quotations shall be submitted net of any direct taxes and any other taxes and duties, unless otherwise specified in the requirements section.</p> <p>All prices must: <input checked="" type="checkbox"/> be exclusive of VAT and other applicable indirect taxes</p>
Eligibility	<p>A vendor who will be engaged by UNDP may not be suspended, debarred, or otherwise identified as ineligible by any UN Organization or the World Bank Group or any other international Organization. Vendors are therefore required to disclose to UNDP whether they are subject to any sanction or temporary suspension imposed by these organizations. Failure to do so may result in termination of any contract or PO subsequently issued to the vendor by UNDP.</p> <p>It is the Bidder's responsibility to ensure that its ultimate beneficial owners, employees, joint venture members, sub-contractors, service providers, suppliers and/or their employees meet the eligibility requirements as established by UNDP.</p> <p>Bidders must have the legal capacity to enter a binding contract with UNDP and to deliver in the country, or through an authorized representative.</p>
Language of quotation	<p>English or Romanian</p> <p>Including documentation such as catalogues, instructions and operating manuals.</p>
Quotation validity period	<p>Quotations shall remain valid for 90 (ninety) days from the deadline for the Submission of Quotation.</p>
Partial Quotes	<p><input checked="" type="checkbox"/> Not permitted</p>
Alternative Quotes	<p><input checked="" type="checkbox"/> Not permitted</p>
Payment Terms	<p><input checked="" type="checkbox"/> Per deliverable, within 30 days after receipt and acceptance of each deliverable.</p>

Conditions for Release of Payment	<input checked="" type="checkbox"/> Written Acceptance of Services, based on full compliance with RFQ requirements
Clarifications	<p>Bidders must send their inquiries and requests for clarifications using the messaging functionality in the portal.</p> <p>PLEASE PAY ATTENTION: QUOTES SHALL NOT BE SUBMITTED TO ANY EMAIL ADDRESS BUT ONLY THROUGH THE PORTAL.</p> <p>Requests for clarification from bidders will not be accepted any later than 3 (three) days before the submission deadline. Responses to request for clarification will be communicated directly in the portal.</p>
Pre-bidding conference	<p>Will be conducted</p> <p>Date: 05 March 2026</p> <p>Time and time zone: 11:00, (GMT+3, Moldova Local Time)</p> <p>Zoom link: https://undp.zoom.us/j/88032694562?pwd=eXmyPshxBBoP80qTafV81wSWeXjURo.1</p> <p>Zoom Meeting ID: 880 3269 4562</p> <p>Zoom Meeting Passcode: 278528</p> <p><u>Interested bidders should register for the conference.</u></p> <p><u>To facilitate the registration, prospective bidders are required to send the names and email addresses of their authorized representatives using the "Messages" section in Quantum no later than 04 March 2026. In case bidders face any technical difficulties with Quantum platform, they shall send the above-mentioned information to the following email address: sc.md@undp.org.</u></p> <p><u>Please ensure that the subject of the email message is marked as 'PRE-BID CONFERENCE FOR RFQ26/03216'.</u></p> <p><u>The Pre-bid conference is not mandatory but highly recommended.</u></p> <p>Minutes of the Pre-proposal conference will be disseminated by:</p> <p>Direct communication to prospective Bidders by email and posting directly in Quantum and on the below tender websites: UNDP Moldova tenders, UNDP Procurement Notices and UNGM.</p>
Documents to be submitted	<input checked="" type="checkbox"/> Annex 2: Quotation Submission Form duly completed and signed <input checked="" type="checkbox"/> Annex 3: Technical and Financial Offer duly completed and signed and in accordance with the Schedule of Requirements in Annex 1 <input checked="" type="checkbox"/> Company Profile (short info up to 5 pages), including detailed portfolio/previous corporate experience in similar fields related to the assignment <input checked="" type="checkbox"/> Copy of Company's Registration Certificate or Extract from the state register <input checked="" type="checkbox"/> List of completed and/or ongoing contracts for similar design and cost estimation assignments (development of design and costs estimation projects in the Civil and Industrial field with similar type in volume undertaken within the past five (5) years). The list shall include the following information: <ul style="list-style-type: none"> • Name of previous contracts • Client & Reference Contact (clients may be contacted for further information on the respective contracts)

	<ul style="list-style-type: none"> • Details including e-mail • Contract Value Period of activity • Types of works/services undertaken. <p><i>As proof of similar experience, copies from the contract for services and acts/reports of technical design and estimates handled and accepted by the Client/Beneficiary can be requested.</i></p> <p><input checked="" type="checkbox"/> Statement of satisfactory Performance (Certificates) from the top 3 (three) clients in terms of Contract value in similar field (<i>in the field of development of design and costs estimation projects in the Civil and Industrial field</i>). <i>Please also provide reports of technical designs and estimates handled and accepted by the Client/Beneficiary.</i></p> <p><input checked="" type="checkbox"/> List of qualified key personnel (designers), together with dully signed CVs and professional certificates (valid at the date of presentation for min. 1 year)</p> <p><input checked="" type="checkbox"/> Quality Certificates (ISO, etc.) if available</p> <p><input checked="" type="checkbox"/> Chart for execution of works (Work Time Schedule) for example GANTT, which will reflect the activities to be implemented, timeframe, with the involved qualified staff (designers)</p> <p><input checked="" type="checkbox"/> Income Statement and Balance Sheet for the past two years (2024-2025).</p>
Evaluation method	<input checked="" type="checkbox"/> The Contract will be awarded to the lowest price substantially compliant offer.
Evaluation criteria	<input checked="" type="checkbox"/> Full compliance with all requirements as specified in Annex 1: Schedule of Requirements. <input checked="" type="checkbox"/> Full acceptance of the General Conditions of Contract <input checked="" type="checkbox"/> Be a legally registered company <input checked="" type="checkbox"/> Minimum 10 (ten) years of experience in the field of development of design and cost estimation projects in the Civil and Industrial field. <input checked="" type="checkbox"/> Minimum 3 (three) contracts with Acceptance Notes attached for development of design and cost estimation projects in the Civil and Industrial field, undertaken in the last 5 (five) years performed by the bidder as main contractor, with a cumulative value of 105,000 USD. <input checked="" type="checkbox"/> Sufficient human resources capability to qualitatively and timely execute the works. <u>Minimum key-personnel with valid qualification certificates (valid at the date of presentation for min. 1 year) issued by the national regulation authority in construction of Republic of Moldova that will perform works in line with the legislation of Republic of Moldova:</u> <ul style="list-style-type: none"> • One (1) Task Manager / Architect, duly certified, with a minimum of ten (10) years of relevant professional experience in the field. • One (1) Certified Structural/Civil Engineer (part-time), with a minimum of ten (10) years of relevant professional experience. • One (1) Certified Electromechanical Engineer (part-time), with a minimum of five (5) years of relevant professional experience. • One (1) Certified Water Supply and Sanitary Engineer (part-time), with a minimum of five (5) years of relevant professional experience. • One (1) Certified Heating, Ventilation and Air Conditioning (HVAC) Engineer (part-time), with a minimum of five (5) years of relevant professional experience. • One (1) Certified Fire Protection / Protection Installations Engineer (part-time), with a minimum of five (5) years of relevant professional experience. • One (1) Certified Topographer (part-time), with a minimum of five (5) years of relevant professional experience. • One (1) Certified Engineering Geologist (part-time), with a minimum of five (5) years of relevant professional experience. • One (1) Certified Landscape Designer (part-time), with a minimum of five (5) years of relevant professional experience. • One (1) Attested Cost Estimator / Bill of Quantities (BoQ) Specialist, with a minimum of five (5) years of relevant professional experience.

	<input checked="" type="checkbox"/> The proposed key personnel shall have demonstrated experience in the provision of design development services. Submitted CVs shall clearly indicate relevant and consistent professional experience corresponding to the proposed position and responsibilities. <input checked="" type="checkbox"/> Maximum delivery period not to exceed 150 calendar days (applicable to all Voluntary Waste Collection Centers (VWCCs)) upon signature of contract and from the moment the Contractor was given permissive documents (urban certificate, technical conditions for the infrastructure,) and access to the site for survey investigations.
Type of Contract to be awarded	<input checked="" type="checkbox"/> Contract Face Sheet (Goods and-or Services)
Expected date for contract award.	30 March 2026



ANNEX 1: SCHEDULE OF REQUIREMENTS

PROJECT NAME: Enabling an Inclusive Green Transition in the Republic of Moldova

A. Background

On 23rd of June 2022, the European Council granted the Republic of Moldova the status of EU candidate country which is a substantial achievement, but which comes with great responsibilities and obligations. One of such obligation is the “Green Agenda and Sustainable Connectivity” which includes Chapters of the environment and climate change acquis. In this sense, meaningful reform is expected in view of European Green Deal targets.

The Green Transition Project takes due account of this endeavor. Hence, it will put in place the enabling conditions for a green transformation in Moldova through a combination of cross-sectorial decision-making in joint stakeholder platforms, capacity building measures, general education and awareness raising, dissemination of best policy practices, information sharing and networking, as well as pilot-testing green-transition related solutions and other activities, to ensure that the green transition concept is well understood and implemented.

The established enabling conditions and the investments into green-transition solutions will respond to the key development challenges that the country is currently dealing with such as climate change, environmental pollution, and the energy crisis.

It is well acknowledged that Moldova is highly vulnerable to climate change, given the limited resources and institutional capacities to address the climate change impacts. It is also due to the heavy reliance on the agricultural sector, water scarcity and other geographical factors. Currently the country is advancing with the national adaptation planning, including in the agricultural sector, aimed at putting in place proper institutional, technical, and budgeting capacities in the context of climate change, however significant gaps remain in embarking of the sectors into achievement of the long-term adaptation targets.

Environmental degradation is also posing a major threat to Moldova’s development agenda as its economy relies greatly on natural resources which leads to their overexploitation and pollution. Inadequate waste management practices and outdated practices and technologies in the key sectors of the economy also contribute to the environmental degradation and pollution. Mainstreaming of the green agenda into the country’s economic activities is taking place slowly.

Moldova is in line with the global trend of continuously growing urbanization, with the proportion of the population living in urban areas expected to rise from 47% in 2010 to 60% in 2030 (UN Habitat). Cities are increasingly and significantly contributing to the main drivers of global environmental degradation. The

municipalities have the greatest impact on air quality and are responsible for more than 50% of total air pollution in Moldova.

From energy security perspective – Moldova is highly dependent on imported energy sources and rely mostly on the use of fossil fuels. In addition, inefficient energy supply and consumption across all sectors exacerbates the situation. Until recently being 100% dependent on Russian gas import, the country is actively seeking diversification of energy supplies after the war of aggression in Ukraine. Improvements both in energy efficiency and in the development of domestic resources – including renewable energy resources – for strengthened sustainability, competitiveness, and energy security rank high on the political agenda, energy sector and the main source of GHG emissions in the country.

Against this background, the Green Transition Project aims to support the Government of Moldova to engage sustainably in a transformative green agenda by enhancing awareness, building capacities, and encouraging investments into low-emission and resource efficient economy.

The target areas of the project are resource efficiency, green and circular economy, cleaner and sustainable energy, and mobility.

The Project is be implemented under the following three specific components:

1. Socio-economic framework for a gender-responsive and inclusive green transition enabled.
2. Capacity and awareness on the inclusive green transition increased among key stakeholders.
3. Additional funding attracted by promoting and piloting investments in green and innovative technologies, while evidence-based decision-making for green transition is improved by deploying a reliable air quality monitoring system.

The implementation period of the project is 48 months, and the total budget is 10 mln EUR.

Waste management remains a significant environmental challenge in the Republic of Moldova. According to the National Bureau of Statistics, approximately 3 million cubic meters of waste are generated annually from household and commercial activities. However, selective waste collection is only partially implemented, mainly in Chişinău and a limited number of district centers. Data from the Environmental Protection Inspectorate indicates that less than 10 percent of generated waste is currently sorted and recycled, while the remainder is disposed of in approximately 1,100 landfills nationwide, many of which operate without prior sorting or treatment. As a result, recyclable and biodegradable waste streams are commonly landfilled, creating long-term environmental and public health risks.

In response, the Republic of Moldova has committed to strengthening waste management systems in line with national reforms and the EU environmental acquis, with a particular focus on increasing recovery and recycling rates for waste streams subject to Extended Producer Responsibility (EPR) schemes, targeting recycling rates of up to 60 percent in the medium term.

The project “**Enabling an Inclusive Green Transition in the Republic of Moldova**” supports the Ministry of Environment in accelerating the modernization of waste management infrastructure. A core intervention under the project is the development of infrastructure for separate waste collection, reuse, and recovery through the construction of up to three Voluntary Waste Collection Centres (VWCCs). These facilities are intended to serve as key nodes in an integrated municipal waste management system and to improve the collection of bulky waste, construction and demolition waste, end-of-life products, and biodegradable waste streams.

The establishment of VWCCs is mandated by Law No. 209 on Waste, which requires local public authorities to ensure the development and operation of at least one waste collection center per 50,000 inhabitants as part of an integrated waste management system. In this context, a Call for Project Proposals was launched between 20 November and 26 December 2025 to support first-level local public authorities in developing modern infrastructure for separate waste collection. Following a competitive evaluation process conducted in accordance with the Applicant’s Guide, three local public authorities were selected to receive support for the construction of Voluntary Waste Collection Centres.

B. Objective of the assignment

The main objective of the assignment is developing, obtaining legal permits, and approving the execution detailed technical design and costs estimation for the construction of the platform for recyclables including all infrastructure (Voluntary Waste Collection Centres), with a focus on developing comprehensive design documentation (documentation in phases: Preliminary Design (Schita de proiect), Detailed Technical Design (Proiect de execuție) together with Bill of Quantities (BoQ) , cost estimates and all necessary verifications, endorsements and approvals by appropriate authorities. The assignment also includes author supervision during construction works at the selected platform.

The detailed design documentation shall fully address all construction requirements, processes and implementation steps, including a clear description and justification of proposed methodology.

To achieve the objective, the appointed company shall be responsible for preparing and/or the acquisition of all required technical design documentation and approvals, including but not limited to the following:

- Technical drawings and documentation required for obtaining the City Planning Certificate (design permit);
- Preparation of the Preliminary Design (Schita de Proiect) including technical reports and drawing, in compliance with the legislation of Republic of Moldova;
- Preparation of the Execution project (Proiect de execuție), including relevant technical reports and drawings, in compliance with national legislation and conditions imposed by relevant authorities;
- Development of Bills of Quantities (BoQ) and detailed cost estimates based on approved technical drawings;
- Verification, coordination, endorsement, and approval of the design documentation and cost estimates by attested verifiers and relevant public authorities;
- Provision of author supervision throughout the of the construction phase;
- Participation in the commissioning process upon completion of works in accordance with national legislation, including CUC No. 434 of 28 December 2023.

The contractor shall also support to the local authorities in obtaining all required permissive documentation including:

- City planning certificate (design permission);
- Environmental agreement;
- Authorization for connecting to the technical and utility networks, based on required technical documentation.

Indicative platform dimensions:

1. **CAV Călărași** – in accordance with the geometric plan, with recommended dimensions of **50 m × 70 m** (Annex No. 1).
2. **CAV Ungheni** – in accordance with the geometric plan, with recommended dimensions of **50 m × 70 m** (Annex No. 2).
3. **CAV Leova** – in accordance with the geometric plan, with recommended dimensions of **50 m × 70 m** (Annex No. 3).

Key Tasks and Expected Outputs:

Throughout the developing of the detailed design documentation, the appointed company shall ensure:

- Selection of methods, techniques, materials and products compliant with ISO standards;
- Continuous coordination with UNDP Team, beneficiaries, and all relevant stakeholders to ensure technical coherence, integration of all design components, and alignment of proposed solutions.

Minimum Required Design Documentation and Studies

At a minimum, the Contractor shall provide the following execution drawings, studies, and documentation for the concrete platform, associated equipment, and the roofed metal building (CAV):

- Topographical (Topo-geodetic) survey;
- Technical geological survey;
- General plan (PG);
- Stormwater drainage network (RD);
- Architectural and construction solutions (SAC);
- Interior design (IN), (where required);
- Reinforced concrete structures (CBA) (for relevant components);
- Heating, ventilation and air conditioning systems (IVC);
- Internal water supply and sewerage networks (RAC);
- External water supply and sewerage networks (REAC);
- External electrical lighting (IEE);
- Internal electrical lighting (IEI) (where applicable);
- Electricity supply systems (AEE);
- Lightning protection systems (PT);
- Fire alarm and security systems (SIP);
- External electricity supply networks (REAE);
- Construction site organization plan (OLC);
- Landscape design;

- Preliminary cost estimates ;
- Detailed cost estimates and technical specifications for construction works and equipment;
- Technical passports (technical files) for all included equipment;
- Specifications for construction works and procurements (in accordance with the UNDP model)

Additional documentation shall be prepared as required by applicable national construction norms (NCM), city planning (CP), and ISO standards.

Implementation stages:

Stage 1: Site Surveys and Permissive Documentation

At the beginning of this stage, the appointed company shall obtain all required technical conditions and approvals, including:

- a) Connection conditions for utility networks (electricity, water supply, sewerage);
- b) Environmental agreement;
- c) City Planning Certificate (design permit);
- d) Any other site-specific permits required under applicable construction norms.

The Beneficiary shall provide support during the permitting process, as required.

Site investigation activities shall include:

- Topographical, geotechnical and engineering surveys;
- Verification of land ownership/legal status and compliance with on construction regulations; Soil investigations, including surface and subsurface exploration, sampling, and laboratory testing.
- **Stage 2: Preliminary Design (Schița de Proiect)**

The preliminary design of the concrete platform, including the equipment and the roofed metal building (CAV), shall, at a minimum, include the following:

- a. General explanatory note with justification of proposed technical solutions;
- b. Situation plan;
- c. General layout with positioning of structures;
- d. Architectural solutions, including roofed area and site integration;
- e. Utility networks and technical/technological solutions (as applicable);
- f. Construction organization concept;
- g. Preliminary cost estimates based on general indices;
- h. Environmental protection measures;
- i. Fire safety and prevention measures.

The documentation shall be reviewed, discussed and endorsed by the Beneficiary and UNDP.

The contractor shall revise and finalize the documentation in line with comments received.

Stage 3. Detailed Technical Design (Proiect de execuție)

Following approval of the Preliminary Design and issuance of the City Planning Certificate, the Contractor shall, within maximum three (3) weeks, prepare the design theme (methodology, materials, equipment and implementation stages) and coordinate it with the UNDP and the Beneficiary.

The Detailed Technical Design of the concrete platform, including the equipment and the roofed metal building (CAV) shall be developed in compliance with NCM A.07.02-2012/A2017 (procedure for development, endorsement, approval, and framework-content of design documentation for constructions and its amendments in forces) and all applicable national regulations, building norms, and international standards.

The designs shall ensure:

1. Reliable and safe operation of all systems and equipment;
2. Cost efficiency in construction, operation, and maintenance;
3. Compliance with occupational health and safety requirements;
4. Compliance with fire prevention requirements;
5. Compliance with environmental protection requirements.

The Detailed Design documentation shall include the following chapters:

- I. Architectural and civil engineering solutions;
- II. Electrical and lighting systems (internal and external), as agreed with UNDP and the Beneficiary;
- III. Water supply, fire protection, and sanitation systems.
- IV. Rainwater collection and filtration systems;
- V. Video security system;
- VI. Construction site organization (OLC);
- VII. Environment protection measures;
- VIII. Detailed BoQ in accordance with national building norms.

The Contractor shall be responsible for verification, coordination, and endorsement of the documentation by attested verifiers and relevant authorities.

All associated costs, fees and charges shall be borne by the Contractor and included in the financial offer.

Stage 4. Author Supervision During Construction

During construction, the Contractor shall provide author supervision in accordance with applicable regulations.

This includes:

- Addressing discrepancies between design documentation and site conditions;
- Proposing and documenting necessary technical adjustments, subject to prior approval by UNDP and the Beneficiary;
- Ensuring that any material substitutions meet or exceed the originally specified technical characteristics.

All revised documentation shall be re-verified and re-endorsed in compliance with legislation, at the Contractor's expense.

The Contractor shall participate in the preliminary commissioning and handover of works and issue the Author's Compliance Certificate (Avizul proiectantului). **Please note: the final commissioning of the works (Certificate of Final Completion) will take place 12 months after the Defect Liability Period (DLP) which begins after initial completion/handover of works (Certificate of Substantial Completion).**

C. General Regulatory Framework

For the purposes of contract implementation, the selected Contractor shall comply with all applicable legislation and normative acts in force in Republic of Moldova. In particular, the Contractor shall be guided by, but not limited to, the following regulatory documents:

- 1) Urban and Construction Code (CUC) No.434 of 28 December 2023;
- 2) NCM A.07.02-2012/A2017- Procedure for development, endorsement, approval and framework-content of design documentation for constructions, including all subsequent its amendments;
- 3) NCM E.03.02-2014- Fire protection for buildings and installations;
- 4) NCM E.04.04-2016- Protection against environmental actions, Design of anticorrosive protection of constructions;
- 5) SNiP 2.04.02-84 - Water supply. External networks and facilities;
- 6) NCM B.01.03-2005 - General plans of industrial enterprises;
- 7) NCM C.04.03-2015- Design rules for coverings;
- 8) NCM G.03.03-2015- Internal water supply and sewerage installations;
- 9) NCM G.03.02-2015-External water supply and sewerage installations;
- 10) NCM E.03.03:2018- Fire safety: Fire detection, signaling and warning systems;
- 11) NCM E.01.02:2019-Fire safety: Regulation on the establishment of construction importance categories;
- 12) CPL 01.01-2012- Instructions for preparing cost estimates for construction and installation works based on the resource-based method;
- 13) NCM A 07.03-2002- Regulation on author's supervision during construction works;
- 14) Any other applicable normative acts, standards, and regulations in force on the territory of the Republic of Moldova.

Implementation timeframe

The maximum duration for the provision of design services shall not exceed 150 calendar days (applicable to all Voluntary Waste Collection Centers (VWCCs)).

The anticipated commencement date of the contract is March 2026.

UNDP shall require up to fourteen (14) calendar days, depending on the stage of implementation, to review submitted deliverables, provide feedback and comments, and issue approval of formal acceptance of the deliverables, in accordance with UNDP quality assurance and contractual procedures.

D. Deliverables and Timeframe

The Contractor shall provide the required design and related services in accordance with the following deliverables and timelines outlined below:

Item No.	Description/Specification of provided services	Delivery Date
1.	Deliverable 1: Preliminary Site Investigations and Surveys -Topographic survey of the site; -Geotechnical investigations, including soil sampling and laboratory testing of retrieved samples; -Obtaining all required permits, approvals, and permissive documentation necessary for design development.	Up to 40 calendar days from the date of contract signing
2.	Deliverable 2: Development of the Preliminary Design of the concrete platform, including the equipment and the roofed metal building (CAV) (Schița de Proiect)* -Preparation of design sketches in compliance with site conditions, applicable standards, performance requirements, greening principles and accessibility requirements; -Formulation, assessment and comparison of design options; -Development of a conceptual design for the selected “passed-screening” option;	Up to 55 calendar days from the date of contract signing
3.	Deliverable 3: Development of Detailed Project Documentation of the concrete platform, including the equipment and the roofed metal building (CAV) (Proiect de execuție)** The detailed design package shall include, but not be limited to: -Architectural and structural/construction solutions (SAC); -External electrical lighting networks (REE/REI to be confirmed during the Design Theme development stage); -Water supply and sanitation systems; -Rainwater collection, drainage, and treatment, -Video security system; -Environmental protection chapter; -Construction site organization plan (OLC);	Up to 150 calendar days from the date of contract signing

	-Bills of Quantities (BoQ) and cost estimates in accordance with applicable national norms and standards.	
4.	Deliverable 4: Design Author's Supervision during the construction works Provision of design author's supervision services throughout the construction phase to ensure compliance with the approved design documentation.	During the construction period, tentatively until 28 May 2027 (with possible extension)

Notes and Submission Requirements:

- Deliverables shall be assessed and accepted separately for each location (Călărași, Ungheni, and Leova).
- All deliverables shall be prepared and submitted in Romanian or English language;
- All design documentation and technical specifications shall be submitted in:
 - Hard copy: Four (4) printed copies, duly signed and endorsed; and
 - Electronic format: Scanned versions of the signed hard copies, provided on a flash-drive;
- In addition, the design documentation shall be provided in the following editable formats:
 - Drawings: DWG format;
 - Explanatory notes: Microsoft Word format;
 - Cost estimates : .kos format.

- Drawings must be submitted in:
 - Each drawing shall be saved as separate PDF/JPG format;
 - PDF/JPG files shall be generated directly from AutoCAD using the "Print to PDF/JPG" function;
 - Scanned copies of printed drawings shall not be accepted as scaled PDF/JPG files.

* Coordination and endorsement of the Preliminary Design with the Beneficiary, UNDP and relevant authorities.

** Coordination and endorsement of the detailed design documentation with the UNDP and the Beneficiary. Independent verification of the detailed design by authorized/ licensed experts. Endorsement and approval of detailed project documentation by the relevant competent authorities.

E. Institutional Arrangements

The Contractor shall coordinate all activities under this Contract with the Green Transition Project Institutional Development and Capacity Building Manager, under the overall supervision of the Green Transition Project Manager, UNDP Moldova. UNDP Moldova, through the Green Transition Project, shall provide all available and relevant background documentation, facilitate initial contacts, support communication with relevant stakeholders, and ensure access to project sites, as required. The Contractor shall be fully responsible for arranging all necessary transportation and logistical arrangements, obtaining all required permits and authorizations in accordance with national legislation of the Republic of Moldova, and establishing and maintaining effective working relationships with all involved parties. All costs related to written and oral translation and interpretation services shall be borne by the Contractor.

The assignment will be implemented partially on a home- or office-based basis and will include field missions within the Republic of Moldova. All travel and subsistence costs related to the assignment, including transportation to and from the assignment locations, shall be the responsibility of the Contractor and must be included in the financial offer.

The Bidder shall ensure the availability of adequate human resources, technical capacity, equipment, and working materials necessary for the timely and high-quality delivery of services at all stages of the assignment, including the design and implementation phases.

Prior to the commencement of the assignment, the Contractor shall participate in a kick-off meeting with representatives of UNDP Moldova to agree on the implementation approach, work plan, reporting arrangements, and coordination mechanisms.

Confidentiality

Materials provided to the Contractor and all proceedings within the contract shall be regarded as confidential, both during the term, including any extension thereof, and shall remain effective following termination or expiration of the Contract, and are only to be used in connection with the execution of these.

Information and data that is delivered or disclosed by UNDP during the course of performance of the Contract, and that has been designated as confidential at the time of exchange or promptly identified as confidential in writing when furnished in intangible form or disclosed orally, as well as information that the Contractor knows or should have reasonably known from its inherent nature, quality or characteristics that is proprietary or confidential shall be held in confidence by the Contractor.

Financial Arrangements

Payments are based upon output, i.e. upon delivery of the services specified in the TOR and submission of deliverables, as to be agreed at contract signature stage. All envisaged costs must be included in the Annex 3. TECHNICAL AND FINANCIAL OFFER. In order to assist the requesting unit in the comparison of financial proposals, the financial proposal will include a breakdown of costs (including the unit process, daily fee, taxes, number of anticipated working days, etc.).

The payment for services will be made in tranches upon submission of deliverables stated in point D. Deliverables and Timeframe, and certification by the Project Manager that the services were satisfactorily performed. All the deliverables envisaged in the Contract shall be coordinated and agreed upon with companies and further endorsed by the Project Manager within 14 calendar days since the moment they are submitted.

In accordance with UNDP Financial Rules and Regulations, advance payments are not permitted. Payments shall be made only upon completion of contractual obligations and certification of satisfactory performance.

F. Qualifications of the Successful Service Provider at Various Levels

Bidders should describe, in detail (Company Profile), their previous corporate experience in similar relation to the project's assignment.

Bids will be evaluated based on compliance with the qualification requirements outlined in Section 3: Special Instructions.

The Bidder shall be a legally registered design institution/company or a consortium of such entities, in accordance with applicable legislation.

The proposal shall include the minimum key personnel aimed at implementing said contract.

The minimum key personnel enlisted in Section 3 of this RFQ shall possess valid technical certificates issued by the national regulation authority in construction of Republic of Moldova.

All activities under this assignment shall be implemented in a gender-sensitive manner and in line with green principles and a human rights-based approach.

The Contractor shall take all reasonable measures to ensure that all personnel engaged under this assignment respect local customs and adhere to the highest standards of moral and ethical conduct, in full alignment with UNDP values, including respect for human rights, gender equality, and diversity. This includes respect for differences in culture, gender, religion, ethnicity, nationality, language, age, HIV status, disability, sexual orientation, or any other status. UNDP Moldova reserves the right to request, at any time, the withdrawal or replacement of any key personnel who fail to comply with these standards. Any such replacement shall be carried out at the Contractor's own expense.

Each Bidder shall submit a Technical Offer containing all information requested in Annex 3 – Technical and Financial Offer. The Technical Offer shall include a detailed proposed work plan with indicative timelines for all deliverables outlined in the Terms of Reference, as well as a clear approach for meeting all agreed and additional deadlines, if any.

ANNEX 2: QUOTATION SUBMISSION FORM

Bidders are requested to complete this form, including the Company Profile and Bidder's Declaration, sign it and return it as part of their quotation along with Annex 3: Technical and Financial Offer. Bidders shall fill in this form in accordance with the instructions indicated. No alterations to its format shall be permitted and no substitutions shall be accepted.

Name of Bidder:	Click or tap here to enter text.	
RFQ reference:	RfQ26/03216	Date: Click or tap to enter a date.

Company Profile

Item Description	Detail
Legal name of bidder or Lead entity for JVs	Click or tap here to enter text.
Legal Address, City, Country	Click or tap here to enter text.
Website	Click or tap here to enter text.
Year of Registration	Click or tap here to enter text.
Legal structure	Choose an item.
Are you a UNGM registered vendor?	<input type="checkbox"/> Yes <input type="checkbox"/> No If yes, insert UNGM Vendor Number
Quality Assurance Certification (e.g. ISO 9000 or Equivalent) (If yes, provide a Copy of the valid Certificate):	<input type="checkbox"/> Yes <input type="checkbox"/> No
Does your Company hold any accreditation such as ISO 14001 or ISO 14064 or equivalent related to the environment? (If yes, provide a Copy of the valid Certificate):	<input type="checkbox"/> Yes <input type="checkbox"/> No
Does your Company have a written Statement of its Environmental Policy? (If yes, provide a Copy)	<input type="checkbox"/> Yes <input type="checkbox"/> No
Does your organization demonstrate significant commitment to sustainability	<input type="checkbox"/> Yes <input type="checkbox"/> No

through some other means, for example internal company policy documents on women empowerment, renewable energies or membership of trade institutions promoting such issues <i>(If yes, provide a Copy)</i>				
Is your company a member of the UN Global Compact	<input type="checkbox"/> Yes <input type="checkbox"/> No			
Bank Information	Bank Name: Click or tap here to enter text. Bank Address: Click or tap here to enter text. IBAN: Click or tap here to enter text. SWIFT/BIC: Click or tap here to enter text. Account Currency: Click or tap here to enter text. Bank Account Number: Click or tap here to enter text.			
Previous relevant experience: three (3) contracts completed within the last five (5) years for the development of design documentation and cost estimates for similar projects related to the construction of industrial facilities (for construction of buildings, including engineering systems: heating, ventilation, air-conditioning, electricity, low voltage, video security, anti-fire warning, internet, water/sewerage).				
Name of previous contracts	Client & Reference Contact Details including e-mail	Contract Value <i>(insert currency)</i>	Period of activity <i>(month/year)</i>	Types of activities undertaken

Bidder's Declaration

Yes	No	
<input type="checkbox"/>	<input type="checkbox"/>	Requirements and Terms and Conditions: I/We have read and fully understand the RFQ, including the RFQ Information and Data, Schedule of Requirements, the General Conditions of Contract, and any Special Conditions of Contract. I/we confirm that the Bidder agrees to be bound by them.
<input type="checkbox"/>	<input type="checkbox"/>	I/We confirm that the Bidder has the necessary capacity, capability, and necessary licenses to fully meet or exceed the Requirements and will be available to deliver throughout the relevant Contract period.

Yes	No	
<input type="checkbox"/>	<input type="checkbox"/>	Ethics: In submitting this Quote I/we warrant that the bidder: has not entered into any improper, illegal, collusive or anti-competitive arrangements with any Competitor; has not directly or indirectly approached any representative of the Buyer (other than the Point of Contact) to lobby or solicit information in relation to the RFQ ;has not attempted to influence, or provide any form of personal inducement, reward or benefit to any representative of the Buyer.
<input type="checkbox"/>	<input type="checkbox"/>	I/We confirm to undertake not to engage in proscribed practices, , or any other unethical practice, with the UN or any other party, and to conduct business in a manner that averts any financial, operational, reputational or other undue risk to the UN and we have read the United Nations Supplier Code of Conduct: https://www.un.org/Depts/ptd/about-us/un-supplier-code-conduct and acknowledge that it provides the minimum standards expected of suppliers to the UN.
<input type="checkbox"/>	<input type="checkbox"/>	Conflict of interest: I/We warrant that the bidder has no actual, potential, or perceived Conflict of Interest in submitting this Quote or entering a Contract to deliver the Requirements. Where a Conflict of Interest arises during the RFQ process the bidder will report it immediately to the Procuring Organisation’s Point of Contact.
<input type="checkbox"/>	<input type="checkbox"/>	Prohibitions and Sanctions: I/We hereby declare that our firm, ultimate beneficial owners, affiliates or subsidiaries or employees, including any JV/Consortium members or subcontractors or suppliers for any part of the contract is not under procurement prohibition by the United Nations, including but not limited to prohibitions derived from the Compendium of United Nations Security Council Sanctions Lists and have not been suspended, debarred, sanctioned or otherwise identified as ineligible by any UN Organization or the World Bank Group or any other international Organization.
<input type="checkbox"/>	<input type="checkbox"/>	Bankruptcy: I/We have not declared bankruptcy, are not involved in bankruptcy or receivership proceedings, and there is no judgment or pending legal action against them that could impair their operations in the foreseeable future.
<input type="checkbox"/>	<input type="checkbox"/>	Offer Validity Period: I/We confirm that this Quote, including the price, remains open for acceptance for the Offer Validity.
<input type="checkbox"/>	<input type="checkbox"/>	I/We understand and recognize that you are not bound to accept any Quotation you receive, and we certify that the goods offered in our Quotation are new and unused.
<input type="checkbox"/>	<input type="checkbox"/>	By signing this declaration, the signatory below represents, warrants and agrees that he/she has been authorised by the Organization/s to make this declaration on its/their behalf.

Signature: _____

Name: Click or tap here to enter text.

Title: Click or tap here to enter text.

Date: Click or tap to enter a date.

ANNEX 3: TECHNICAL AND FINANCIAL OFFER – SERVICES

Bidders are requested to complete this form, sign it and return it as part of their quotation along with Annex 2 Quotation Submission Form. The Bidder shall fill in this form in accordance with the instructions indicated. No alterations to its format shall be permitted and no substitutions shall be accepted.

Name of Bidder:	Click or tap here to enter text.	
RFQ reference:	RfQ26/03216	Date: Click or tap to enter a date.

Financial Offer

Provide a lump sum for the provision of the services stated in the Terms of Reference your technical offer. Each deliverable is repeated 3 times as per the number of locations provided (Calarasi, Ungheni, Leova) thus the per line amounts shall be included in the financial offer as per below tables. The lump sum should include all costs of preparing and delivering the Services. All daily rates shall be based on an eight-hour working day.

Currency of the Quotation: MDL (Moldovan Lei) for local bidders and USD (US Dollars) for foreign bidders VAT exclusive:

Location 1: Călărași

Deliverable / Activity description	Professional Fees				Other Costs				Total Amount per deliverable (subtotal 1 + subtotal 2)
	Position	Daily fee Rate	No. of Working Days	Total Amount	Description	Q-ty	Price	Total	
Deliverable 1: Preliminary Site Investigations and Surveys	One (1) Task Manager / Architect, duly certified				Travel (if any)				
	One (1) Certified Structural/Civil Engineer (part-time)				Local transportation costs (if any)				
	One (1) Certified Electromechanical Engineer (part-time)				Communication Expenses				
	One (1) Certified Water Supply and Sanitary Engineer (part-time)				Other costs (please specify)				
	One (1) Certified Heating, Ventilation and Air								

	Conditioning (HVAC) Engineer (part-time)								
	One (1) Certified Fire Protection / Protection Installations Engineer (part-time)								
	One (1) Certified Topographer (part-time)								
	One (1) Certified Engineering Geologist (part-time)								
	One (1) Certified Landscape Designer (part-time)								
	One (1) Attested Cost Estimator / Bill of Quantities (BoQ) Specialist								
				Sub-total 1				Sub-total 2	
									Total:
Deliverable 2: Development of the Preliminary Design of the concrete platform, including the equipment and the roofed metal building (CAV) (Schița de Proiect)	One (1) Task Manager / Architect, duly certified				Travel				
	One (1) Certified Structural/Civil Engineer (part-time)				Subsistence allowance				
	One (1) Certified Electromechanical Engineer (part-time)				Local transportation costs				
	One (1) Certified Water Supply and Sanitary Engineer (part-time)				Communication				
	One (1) Certified Heating, Ventilation and Air Conditioning (HVAC) Engineer (part-time)				Other costs (specify)				
	One (1) Certified Fire Protection / Protection Installations Engineer (part-time)								
	One (1) Certified Topographer (part-time)								
	One (1) Certified Engineering Geologist (part-time)								

	One (1) Certified Landscape Designer (part-time)								
	One (1) Attested Cost Estimator / Bill of Quantities (BoQ) Specialist								
		Sub-total 1				Sub-total 2			
Total:									
Deliverable 3: Development of Detailed Project Documentation of the concrete platform, including the equipment and the roofed metal building (CAV) (Proiect de execuție)	One (1) Task Manager / Architect, duly certified				Travel (if any)				
	One (1) Certified Structural/Civil Engineer (part-time)				Local transportation costs (if any)				
	One (1) Certified Electromechanical Engineer (part-time)				Communication Expenses				
	One (1) Certified Water Supply and Sanitary Engineer (part-time)				Other costs (please specify)				
	One (1) Certified Heating, Ventilation and Air Conditioning (HVAC) Engineer (part-time)								
	One (1) Certified Fire Protection / Protection Installations Engineer (part-time)								
	One (1) Certified Topographer (part-time)								
	One (1) Certified Engineering Geologist (part-time)								
	One (1) Certified Landscape Designer (part-time)								
	One (1) Attested Cost Estimator / Bill of Quantities (BoQ) Specialist								
		Sub-total 1				Sub-total 2			
	Total:								
	One (1) Task Manager / Architect, duly certified				Travel				

Deliverable 4: Deliverable 4: Design Author's Supervision during the construction works	One (1) Certified Structural/Civil Engineer (part-time)				Subsistence allowance					
	One (1) Certified Electromechanical Engineer (part-time)				Local transportation costs					
	One (1) Certified Water Supply and Sanitary Engineer (part-time)				Communication					
	One (1) Certified Heating, Ventilation and Air Conditioning (HVAC) Engineer (part-time)				Other costs (specify)					
	One (1) Certified Fire Protection / Protection Installations Engineer (part-time)									
	One (1) Certified Topographer (part-time)									
	One (1) Certified Engineering Geologist (part-time)									
	One (1) Certified Landscape Designer (part-time)									
	One (1) Attested Cost Estimator / Bill of Quantities (BoQ) Specialist									
		Sub-total 1				Sub-total 2				
	Total:									

Location 2: Ungheni

Currency of the proposal: USD (US Dollars), VAT exclusive:

Deliverable / Activity description	Professional Fees				Other Costs				Total Amount per deliverable (subtotal 1 + subtotal 2)
	Position	Daily fee Rate	No. of Working Days	Total Amount	Description	Q-ty	Price	Total	
Deliverable 1: Preliminary Site Investigations and Surveys	One (1) Task Manager / Architect, duly certified				Travel (if any)				
	One (1) Certified Structural/Civil Engineer (part-time)				Local transportation costs (if any)				
	One (1) Certified Electromechanical Engineer (part-time)				Communication Expenses				
	One (1) Certified Water Supply and Sanitary Engineer (part-time)				Other costs (please specify)				
	One (1) Certified Heating, Ventilation and Air Conditioning (HVAC) Engineer (part-time)								
	One (1) Certified Fire Protection / Protection Installations Engineer (part-time)								
	One (1) Certified Topographer (part-time)								
	One (1) Certified Engineering Geologist (part-time)								
	One (1) Certified Landscape Designer (part-time)								
	One (1) Attested Cost Estimator / Bill of Quantities (BoQ) Specialist								
				Sub-total 1			Sub-total 2		

Deliverable 2: Development of the Preliminary Design of the concrete platform, including the equipment and the roofed metal building (CAV) (Schița de Proiect)	One (1) Task Manager / Architect, duly certified				Travel					
	One (1) Certified Structural/Civil Engineer (part-time)				Subsistence allowance					
	One (1) Certified Electromechanical Engineer (part-time)				Local transportation costs					
	One (1) Certified Water Supply and Sanitary Engineer (part-time)				Communication					
	One (1) Certified Heating, Ventilation and Air Conditioning (HVAC) Engineer (part-time)				Other costs (specify)					
	One (1) Certified Fire Protection / Protection Installations Engineer (part-time)									
	One (1) Certified Topographer (part-time)									
	One (1) Certified Engineering Geologist (part-time)									
	One (1) Certified Landscape Designer (part-time)									
	One (1) Attested Cost Estimator / Bill of Quantities (BoQ) Specialist									
		Sub-total 1					Sub-total 2			
	Total:									
Deliverable 3: Development of Detailed Project Documentation of the concrete platform, including the equipment and the roofed metal building (CAV)	One (1) Task Manager / Architect, duly certified				Travel (if any)					
	One (1) Certified Structural/Civil Engineer (part-time)				Local transportation costs (if any)					
	One (1) Certified Electromechanical Engineer (part-time)				Communication Expenses					

(Proiect de execuție)	One (1) Certified Water Supply and Sanitary Engineer (part-time)				Other costs (please specify)				
	One (1) Certified Heating, Ventilation and Air Conditioning (HVAC) Engineer (part-time)								
	One (1) Certified Fire Protection / Protection Installations Engineer (part-time)								
	One (1) Certified Topographer (part-time)								
	One (1) Certified Engineering Geologist (part-time)								
	One (1) Certified Landscape Designer (part-time)								
	One (1) Attested Cost Estimator / Bill of Quantities (BoQ) Specialist								
		Sub-total 1				Sub-total 2			
Total:									
Deliverable 4: Deliverable 4: Design Author's Supervision during the construction works	One (1) Task Manager / Architect, duly certified				Travel				
	One (1) Certified Structural/Civil Engineer (part-time)				Subsistence allowance				
	One (1) Certified Electromechanical Engineer (part-time)				Local transportation costs				
	One (1) Certified Water Supply and Sanitary Engineer (part-time)				Communication				
	One (1) Certified Heating, Ventilation and Air Conditioning (HVAC) Engineer (part-time)				Other costs (specify)				
	One (1) Certified Fire Protection / Protection								

	Installations Engineer (part-time)								
	One (1) Certified Topographer (part-time)								
	One (1) Certified Engineering Geologist (part-time)								
	One (1) Certified Landscape Designer (part-time)								
	One (1) Attested Cost Estimator / Bill of Quantities (BoQ) Specialist								
			Sub-total 1				Sub-total 2		
									Total:

Location 3: Leova

Currency of the proposal: USD (US Dollars), VAT exclusive:

Deliverable / Activity description	Professional Fees				Other Costs				Total Amount per deliverable (subtotal 1 + subtotal 2)
	Position	Daily fee Rate	No. of Working Days	Total Amount	Description	Q-ty	Price	Total	
Deliverable 1: Preliminary Site Investigations and Surveys	One (1) Task Manager / Architect, duly certified				Travel (if any)				
	One (1) Certified Structural/Civil Engineer (part-time)				Local transportation costs (if any)				
	One (1) Certified Electromechanical Engineer (part-time)				Communication Expenses				
	One (1) Certified Water Supply and Sanitary Engineer (part-time)				Other costs (please specify)				
	One (1) Certified Heating, Ventilation and Air Conditioning (HVAC) Engineer (part-time)								
	One (1) Certified Fire Protection / Protection Installations Engineer (part-time)								
	One (1) Certified Topographer (part-time)								
	One (1) Certified Engineering Geologist (part-time)								
	One (1) Certified Landscape Designer (part-time)								
	One (1) Attested Cost Estimator / Bill of Quantities (BoQ) Specialist								
				Sub-total 1			Sub-total 2		
								Total:	

Deliverable 2: Development of the Preliminary Design of the concrete platform, including the equipment and the roofed metal building (CAV) (Schița de Proiect)	One (1) Task Manager / Architect, duly certified				Travel				
	One (1) Certified Structural/Civil Engineer (part-time)				Subsistence allowance				
	One (1) Certified Electromechanical Engineer (part-time)				Local transportation costs				
	One (1) Certified Water Supply and Sanitary Engineer (part-time)				Communication				
	One (1) Certified Heating, Ventilation and Air Conditioning (HVAC) Engineer (part-time)				Other costs (specify)				
	One (1) Certified Fire Protection / Protection Installations Engineer (part-time)								
	One (1) Certified Topographer (part-time)								
	One (1) Certified Engineering Geologist (part-time)								
	One (1) Certified Landscape Designer (part-time)								
	One (1) Attested Cost Estimator / Bill of Quantities (BoQ) Specialist								
		Sub-total 1					Sub-total 2		
Total:									
Deliverable 3: Development of Detailed Project Documentation of the concrete platform, including the equipment and	One (1) Task Manager / Architect, duly certified				Travel (if any)				
	One (1) Certified Structural/Civil Engineer (part-time)				Local transportation costs (if any)				
	One (1) Certified Electromechanical Engineer (part-time)				Communication Expenses				

the roofed metal building (CAV) (Proiect de execuție)	One (1) Certified Water Supply and Sanitary Engineer (part-time)				Other costs (please specify)				
	One (1) Certified Heating, Ventilation and Air Conditioning (HVAC) Engineer (part-time)								
	One (1) Certified Fire Protection / Protection Installations Engineer (part-time)								
	One (1) Certified Topographer (part-time)								
	One (1) Certified Engineering Geologist (part-time)								
	One (1) Certified Landscape Designer (part-time)								
	One (1) Attested Cost Estimator / Bill of Quantities (BoQ) Specialist								
		Sub-total 1				Sub-total 2			
Total:									
Deliverable 4: Deliverable 4: Design Author's Supervision during the construction works	One (1) Task Manager / Architect, duly certified				Travel				
	One (1) Certified Structural/Civil Engineer (part-time)				Subsistence allowance				
	One (1) Certified Electromechanical Engineer (part-time)				Local transportation costs				
	One (1) Certified Water Supply and Sanitary Engineer (part-time)				Communication				
	One (1) Certified Heating, Ventilation and Air Conditioning (HVAC) Engineer (part-time)				Other costs (specify)				
	One (1) Certified Fire Protection / Protection								

	Installations Engineer (part-time)								
	One (1) Certified Topographer (part-time)								
	One (1) Certified Engineering Geologist (part-time)								
	One (1) Certified Landscape Designer (part-time)								
	One (1) Attested Cost Estimator / Bill of Quantities (BoQ) Specialist								
		Sub-total 1				Sub-total 2			
Total:									

Compliance with Requirements

Requirements	You Responses		
	Yes, we will comply	No, we cannot comply	If you cannot comply, pls. indicate counter - offer
Delivery Lead Time – 150 days	<input type="checkbox"/>	<input type="checkbox"/>	Click or tap here to enter text.
Validity of Quotation – 90 days	<input type="checkbox"/>	<input type="checkbox"/>	Click or tap here to enter text.
Payment terms	<input type="checkbox"/>	<input type="checkbox"/>	Click or tap here to enter text.
<i>Commissioning</i> Participation in preliminary and final commissioning of the works	<input type="checkbox"/>	<input type="checkbox"/>	Click or tap here to enter text.
<i>Technical Support Requirements</i> The contracted company will eliminate any errors in design documentation and costs estimation subject to quality guaranty in maximum 7 days from the moment of written notification	<input type="checkbox"/>	<input type="checkbox"/>	Click or tap here to enter text.
All Provisions of the UNDP General Terms and Conditions accepted	<input type="checkbox"/>	<input type="checkbox"/>	Click or tap here to enter text.

I, the undersigned, certify that I am duly authorized to sign this quotation and bind the company below in event that the quotation is accepted.

Exact name and address of company

Company Name Click or tap here to enter text.

Address: Click or tap here to enter text.

Phone No.: Click or tap here to enter text.

Email Address: Click or tap here to enter text.

Authorized Signature: _____

Date: Click or tap here to enter text.

Name: Click or tap here to enter text.

Functional Title of Authorised Signatory: Click or tap here to enter text.

Email Address: Click or tap here to enter text.

Annex No. 4:

Geometric Plan of Călărași (CAV)



Catalogul de coordonate

Numărul cadastral: 2501216.285

Parametri hotarului

Punct	X_	Y_	Tipul_punct	Hotar	Distanta	Tipul_hotar
1	234.234,2976	193.699,8230	general	1-2	15,35	general
2	234.219,6722	193.695,1600	general	2-3	14,35	general
3	234.206,8668	193.688,6890	general	3-4	41,63	general
4	234.201,6214	193.729,9922	general	4-5	79,06	general
5	234.122,5930	193.727,8944	general	5-6	110,44	general
6	234.182,3236	193.634,9958	general	6-7	73,89	general
7	234.240,9314	193.679,9924	general	7-1	20,91	general

Nivelul de calitate a informatiei grafice pentru teren: 3

Mențiuni:

Cadastral Extract and Geometric Plan of Ungheni (CAV)

06.02.2026, 10:40

9201107.604

Registrul bunurilor imobile 9201107604

Capitolul

A,B (Verificat , 24.06.2020)

Deschis

24.06.2020

Subcapitolul I. Bunul imobil

1.0

Bunul imobil Teren

Numărul cadastral 9201107.604

Adresa r-nul Ungheni, mun. Ungheni str. Lacului, f/n

Modul de fotosință Amenajat

Domeniul Public

Suprafața 1.222 ha

Tipul hotarelor generale

Subcapitolul II. Dreptul de proprietate asupra bunului imobil

2.1

Bunul imobil 9201107.604

Cota parte 1.0

Proprietarul municipiul Ungheni, raionul Ungheni,

Domiciliul / Sediul

Temeiul înscrierii Decizia Consiliului local // Extras // nr. 3/12 din 27.03.2020 (9201/20/6401)

Data înregistrării 15.06.2020

Subcapitolul III. Grevarea drepturilor patrimoniale

Partea I. Alte drepturi înregistrate.

Nu sunt înscrise

Partea II. Notări.

Nu sunt înscrise

Interdicții.

Nu sunt înscrise

Date cu caracter personal

Instituția Publică Cadastrul Bunurilor Imobile

Specialist principal pentru
reglementarea regimului
proprietatii funciare
Mihail COZMOLICI



Primarul mun. Ungheni



PLANUL GEOMETRIC

Numărul cadastral 9201107.604

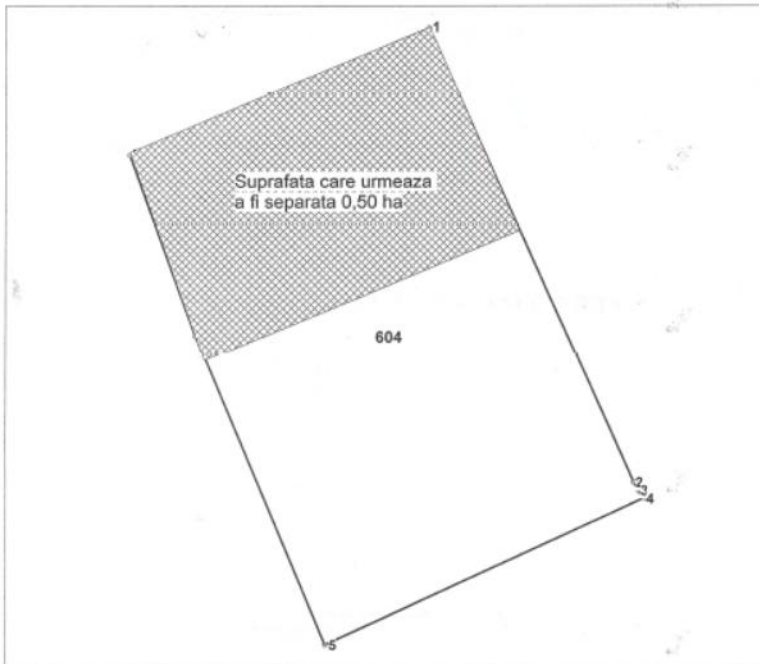

604 - numărul cadastral al terenului
01 - numărul cadastral al clădirii

Caracteristicile tehnice ale bunului imobil

Numar_cadastral	Tipul_bunului	Suprafata	Destinatia	Mod_de_folosinta
9201107.604	Teren	1.222 ha	construcții și amenajări	pentru amplasarea obiectelor gospodăriei comunale

Numărul cadastral: 9201107.604

Catalogul de coordonate și parametrii hotarului.

Punct	X _i	Y _i	Tipul_punct	Hotar	Distanța	Tipul_hotar	Adiacenți
1	154.197,1332	228.552,8954	general	1-2	131,29	general	
2	154.250,9214	228.433,1338	general	2-3	2,77	general	
3	154.252,3152	228.430,7382	general	3-4	2,23	general	
4	154.253,6552	228.428,9564	general	4-5	92,11	general	
5	154.169,9798	228.390,4554	general	5-6	88,19	general	
6	154.136,2390	228.471,9364	general	6-7	50,75	general	
7	154.118,9730	228.519,6630	general	7-1	84,93	general	

Mențiuni:

Cadastral Extract and Geometric Plan of Leova (CAV)

PLANUL GEOMETRIC

Numărul cadastral 5701204.143

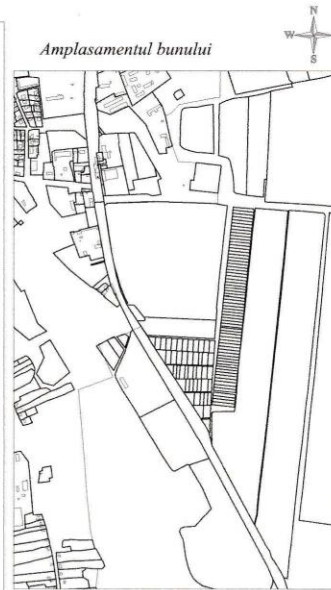
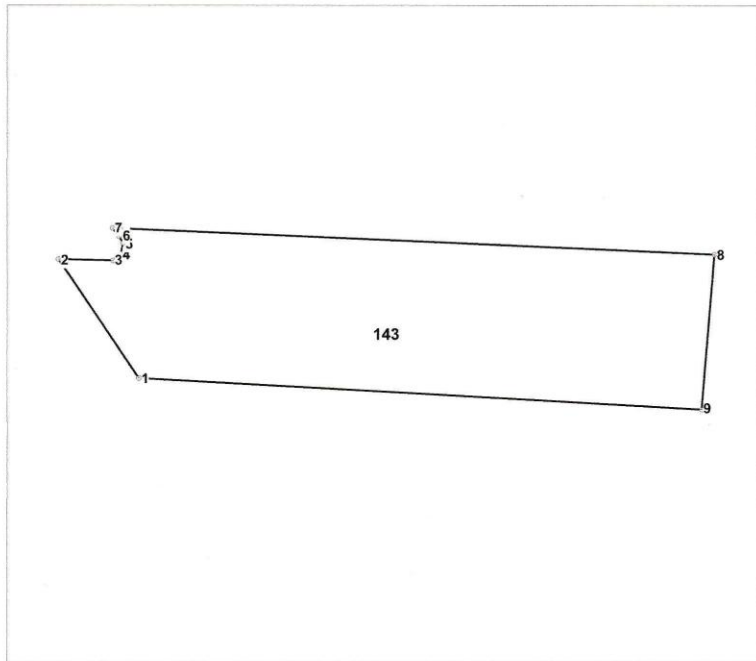

143 - numărul cadastral al terenului
01 - numărul cadastral al clădirii

Caracteristicile tehnice ale bunului imobil

Nr_cadastral	Tipul_bunului	Suprafata	Destinatia	Mod_de_folosinta
5701204.143	Teren	2.0829 ha	Constructii si amenajari	pentru constructii publice

Catalogul de coordonate

Numărul cadastral: 5701204.143

Parametri hotarului

Punct	X_	Y_	Tipul_punct	Hotar	Distanta	Tipul_hotar
1	147.494,8294	189.858,8434	general	1-2	68,24	general
2	147.551,4198	189.820,7134	general	2-3	25,80	general
3	147.550,7892	189.846,5088	general	3-4	4,68	general
4	147.553,6942	189.850,1782	general	4-5	5,46	general
5	147.559,0454	189.851,2486	general	5-6	3,70	general
6	147.562,2560	189.849,4138	general	6-7	5,00	general
7	147.566,1478	189.846,2746	general	7-8	286,92	general
8	147.553,6498	190.132,9270	general	8-9	74,00	general
9	147.479,9018	190.126,8252	general	9-1	268,40	general

Mențiuni:

COORDONAT	
Conducătorul Autorității Publice competente	<i>Bujorean Alexandru</i>
Reprezentantul Autorității Publice competente	<i>Cozma Iurie</i>
Titularul de drepturi	



Registrul bunurilor imobile 5701204143

Capitolul
Deschis

A,B
26.01.2026

Subcapitolul I. Bunul imobil

1.0 Bunul imobil **Teren**
Numărul cadastral **5701204.143**
Adresa **r-nul Leova, or. Leova, extravilan**
Destinația **Pentru construcții și amenajări**
Modul de folosință **Teren pentru amplasarea construcțiilor publice**
Domeniul **Public**
Suprafața **2.0829 ha**
Tipul hotarelor **generale**

Subcapitolul II. Dreptul de proprietate asupra bunului imobil

2.1 Bunul imobil **5701204.143**
Cota parte **1.0**
Proprietarul **orașul Leova raionul Leova,**
Domiciliul / Sediul
Temeiul înscrierii **Decizia Consiliului local nr. 2.19 din 22.02.2017 (5701/26/21083)**
Decizia Consiliului local nr. 5.6. din 20.09.2024 (5701/26/21083)
Decizia privind formarea bunului imobil nr. 1.16 din 18.02.2022 (5701/26/21083)
Decizia privind formarea bunului imobil nr. 2/19 din 12.12.2025 (5701/26/21083)
Decizia privind formarea bunului imobil nr. 8.14 din 13.12.2024 (5701/26/21083)
Data înregistrării **12.01.2026**

Subcapitolul III. Grevarea drepturilor patrimoniale

Partea I. Alte drepturi înregistrate.

Nu sunt înscrieri

Partea II. Notări.

Nu sunt înscrieri

Interdicții.

Nu sunt înscrieri

Date cu caracter personal

Instituția Publică Cadastrul Bunurilor Imobile